

# **Air to Water Heat Pump**

## **Instruction Manual**

For model: GT-SKR200G

GT-SKR300G

- ◆ Please read the manual carefully before installation and maintenance.
- ◆ Please keep this manual well for future reference.

# Contents

Part I: General Information .....	1
1.1 Caution .....	1
Part II Installation & Application .....	2
2.1 Transportation .....	2
2.2 Installation site requirement .....	2
2.3 Minimum clearances for the unit.....	3
2.4 Installation guide .....	3
2.5 Hydraulic connection (for reference).....	4
2.6 Electrical connection .....	5
2.7 Trial Operation .....	6
2.7.1 Preparation .....	6
2.7.2 Trial run.....	6
2.7.3 Caution .....	6
Part III Control System .....	7
3.1 Where is the controller .....	7
3.2 Controller instruction .....	7
3.3 Operation instructions .....	8
Part IV Maintenance.....	12
Part V Trouble shooting.....	13
Part VI Wiring Diagram.....	16
Disposal .....	18

# Part I: General Information

## 1.1 Caution

1. Ensure proper operation on the unit,
2. The unit must be installed and repaired by qualified technician, not consumer.
3. A leakage protection switch must be installed near the unit.
4. Do not use any damaged cables and switches to avoid any leakage.
5. Do not open the electrical box of the unit without shutting off power supply.
6. Along transporting, do not incline the unit more than 45° in any direction.
7. Before maintenance, please shut off the power to the unit first.
8. The outdoor unit may only be installed outdoors. Do not install it in a closed space without good ventilation.
9. Do not install the unit near inflammable or explosive goods.
10. Do not block the air intake or outlet of the unit.
11. When the unit is in off status for more than 5 hours with the ambient temperature lower than 2°C, please drain the unit to prevent the formulation of ice in it.
12. This unit is not intended for operation by persons (including children) with reduced physical, sensory or mental capabilities, or lack of experience or knowledge, unless they have been given supervision or instruction concerning use of the appliance by a person responsible for their safety.
13. Keep safety distance between the unit and other equipment or structures according local norm, and ensure that adequate space for maintenance or service operations.
14. Power supply: the diameter of electrical cables must be suitable for the unit and the power supply voltage must correspond with the value indicated on the units. All units must be earthed in conformity with legislation in force in the country concerned.
15. Please attention that hot water produced by the unit is not used for drink.

# Part II Installation & Application

## 2.1 Transportation

Along transporting , do not incline the unit more than 45° in any direction

The unit in its packaging can be transported with a lift truck or hand truck.

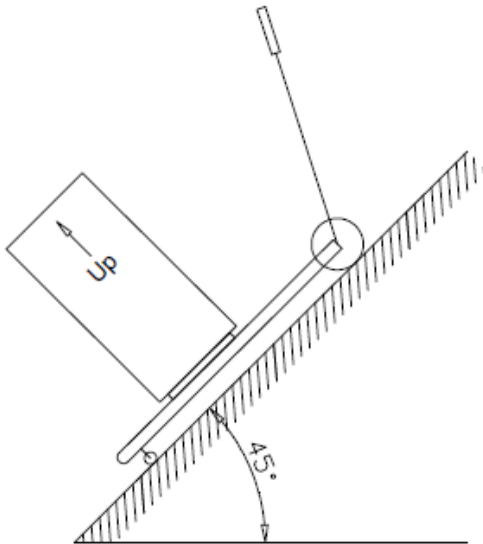

## 2.2 Installation site requirement

The outdoor unit may only be installed outdoors, do not install it in a closed space.

When select a proper place to install the unit, please consider the condition as following:

- The installation place should be large enough and well ventilation.
- The installation place should be convenient for water discharge.
- Select a smooth, horizontal position where it can support the weight of the unit, if necessary you can install the unit on bracket which fix it on wall,
- Do not install the unit where there is pollution, accumulation, fallen leaves or bad ventilation.
- Do not install the unit near inflammable or explosive goods.

## 2.3 Minimum clearances for the unit

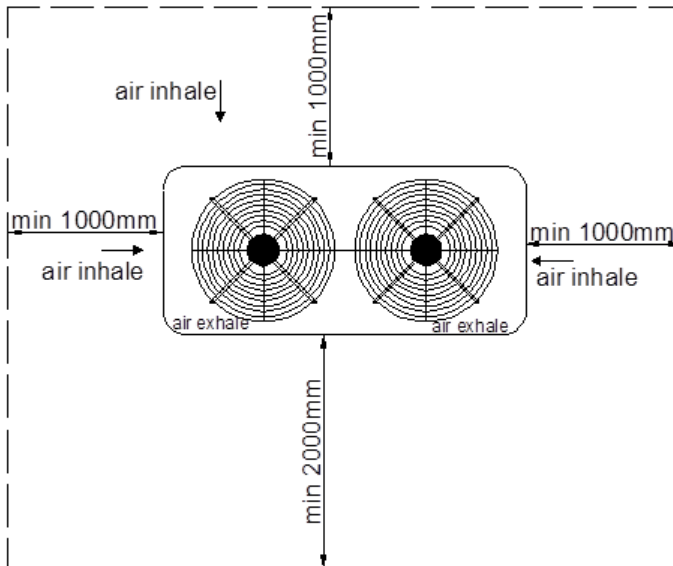

### Clearance between the unit and ground

In areas with heavy snowfall, the minimum installation height must be increased or a canopy must be constructed over the outdoor module.

## 2.4 Installation guide

- a. Install 4 pieces shockproof rubber pad between the feet of the unit and ground.
- b. If install the unit on the wall with bracket, please insure the wall is strong enough.
- c. The vertical distance between the unit and the water tank must be less than 6m, and their horizontal distance should not be more than 20m.
- d. Connect the condensate connector to the drain hole on the bottom sheet.

## 2.5 Hydraulic connection (for reference)

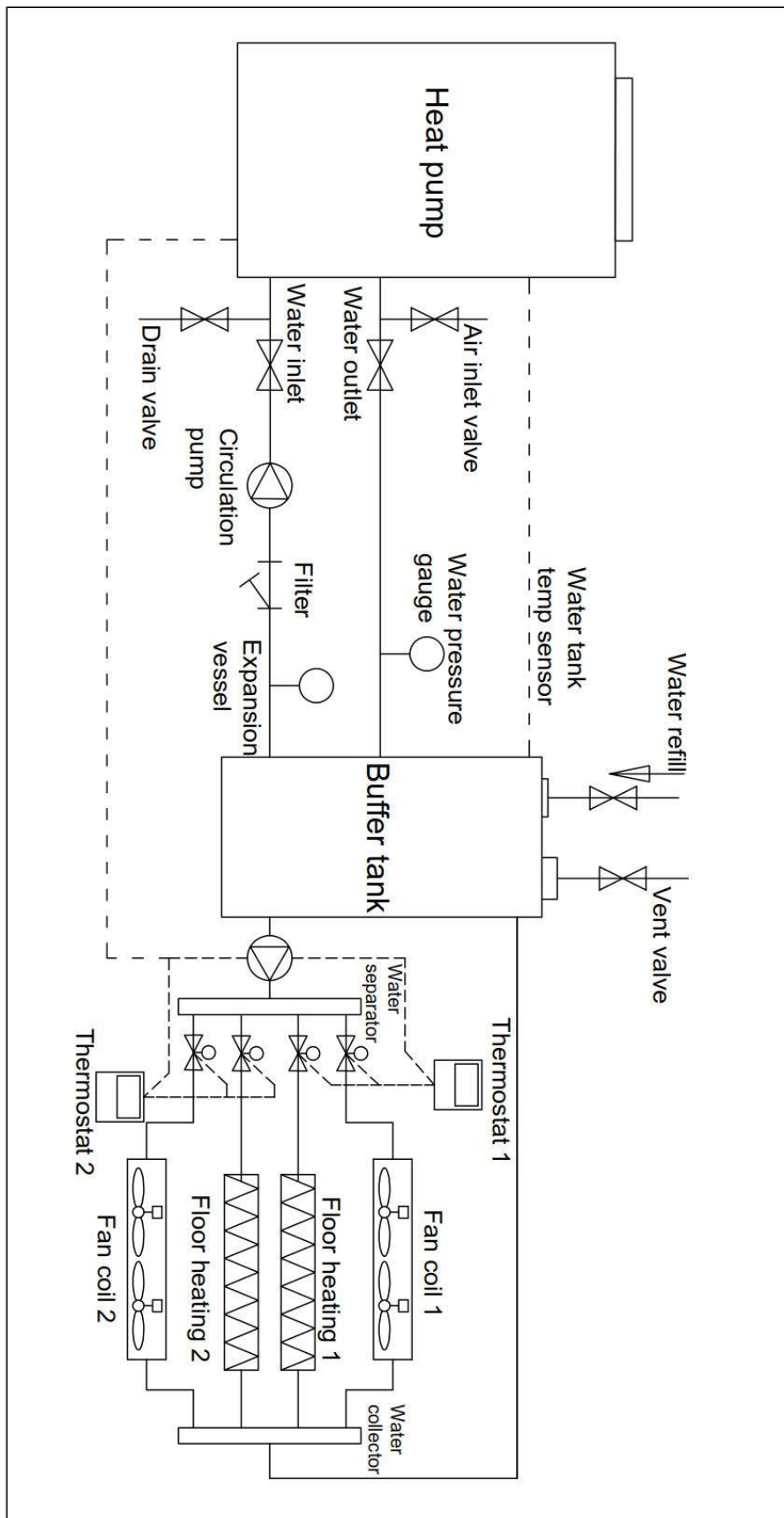

## 2.6 Electrical connection

1. For your own security, and to ensure proper operation of the unit, this heat pump unit must be installed and repaired by qualified technician, not consumer.
  2. A leakage protection switch must be installed near the unit.
  3. Do not use any damaged cable and switch.
  4. Do not open the electrical box without shutting off all power to the unit.
- All the wiring must meet the local electrical safety norm and performed by qualified electricians.
  - Ensure that there is a good earth connection for the power. Do not disconnect the earth connection of the power in any condition.
  - Ensure that the heat pump water heater is well connected to the earth.
  - Provide a separate power supply which meets rated requirements for the unit.
  - When the unit connects to the electricity network, there must be a short-circuit protection.
  - Choose the suitable type of cable when use the power outdoor.
  - Do not control the unit on or off by the main power switch.
  - After finish installation, double check before connect it to the power.

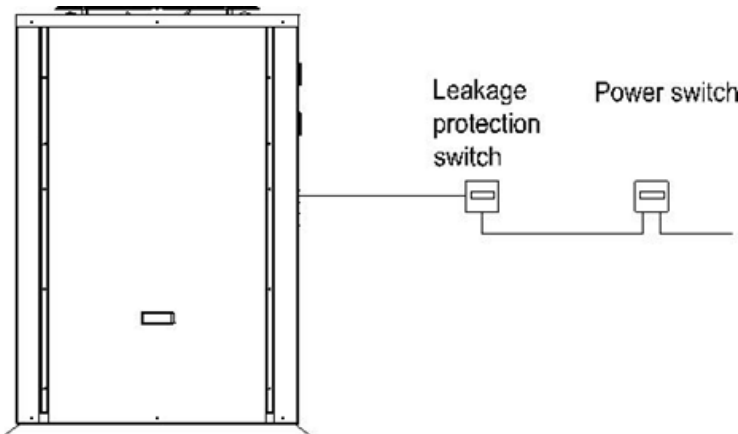

### The Specification of Power (for reference, please subject to local safety norm)

Type	GT-SKR200G	GT-SKR300G
Power supply	380-415V/3Ph/50Hz	380-415V/3Ph/50Hz
Circuit breaker(A)	63	80
Min. power cable (mm <sup>2</sup> )	10	16
Ground wiring (mm <sup>2</sup> )	10	10

## 2.7 Trial Operation

- The unit should only be operated by qualified technician.
- The unit is designed according to the conditions as follows: the range of ambient temperature is  $-7^{\circ}\text{C} \sim 43^{\circ}\text{C}$  and the range of water pressure is  $0.15 \sim 0.6\text{Mpa}$ . The maximum water outlet temperature is  $80^{\circ}\text{C}$ .
- Make sure the piping system and water tank is filled up with water before running.

### 2.7.1 Preparation

The following items need to be checked prior to start-up:

- a. The heat pump must be fully connected.
- b. All valves that could impair the proper flow of the heating water in the heating circuit must be open.
- c. The air intake and air outlet paths must be clear.
- d. The ventilator must turn in the direction indicated by the arrow.
- e. The settings of the heat pump controller must be adapted to the heating system in accordance with the controller's operating instructions.
- f. Ensure the condensate outflow functions.
- g. Drain the air inside piping system.

### 2.7.2 Trial run

- Make sure the piping system is filled up with water before operation.
- Turn on the power, start up the unit by the controller. After the water pump has been running for 30 seconds, the unit starts to work, then observe whether it works normally.
- When you restart the unit, the compressor will start up after three minutes to protect the compressor.

### 2.7.3 Caution

If something happen as follows, please stop the unit immediately and cut off the power. You should contact with our authorized agent or maintenance technician, don't repair by yourselves.

Without professional technology, you may get hurt.

- Fuse blown or protection activated frequently
- The wire and switches are heated abnormally
- Abnormal sounds coming from the unit
- Abnormal smell comes out of the unit.
- Electricity leakage

## Part III Control System

### 3.1 Where is the controller

In order to avoid incorrect operation on the controller by anybody or play by children, the controller is installed in the electrical box before factory, open the front panel, you will see the controller.

It is allowable that relocate the controller outside the electrical box if needed, but do not install the controller in a place where is moist, sunlit or rainy.

### 3.2 Controller instruction

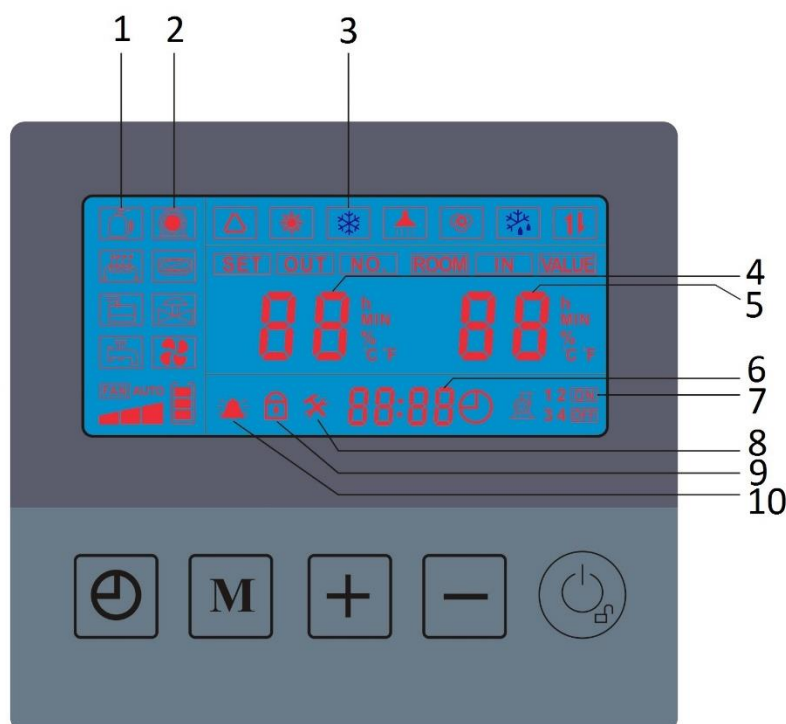



1	Compressor	6	Clock
2	Circulation pump	7	Timer
3	Cooling mode	8	Maintenance
4	Target water temperature	9	Button locked
5	Current water temperature	10	Alarm

### 3.3 Operation instructions



#### A. Lock/Unlock the buttons

1. Unlock the buttons: In lock status, press  for 5 seconds to unlock the buttons.
2. Lock the buttons: In unlock status, no further operation for 2 minutes continuously, lock the buttons automatically.









#### B. On/Off the unit

1. Connect the power supply to the unit, press  to turn on the unit.
2. When the unit is on, press  turn off the unit.

















#### C. Set water temperature

Press  or  to set propose water temperature. Press  to save the setting.









#### D. Set the clock

2. Under ON or OFF status, press  for 5 seconds to enter clock setting status.
3. Press , hour section flash, press  or  to set the hour;
4. Then press , minute section flash, press  or  to set the minute;
5. After setting of minute section, press  or  to save and exit setting.
6. Under clock setting status, if there is no operation on it for 60 seconds, then save current setting and exit setting.

## E. Set or Cancel the timer

1. In main menu, press  to enter ON TIMER setting of timer 1.
2. Press , hour section flash, press  or  to set the hour of ON TIMER of timer 1;
3. Then press , minute section flash, press  or  to set the minute of ON TIMER of timer 1;
4. After ON TIMER setting, press  to enter OFF timer setting of timer 1.
5. Press , hour section flash, press  or  to set the hour of OFF TIMER of timer 1;
6. Then press , minute section flash, press  or  to set the minute of OFF TIMER of timer 1;
7. After OFF TIMER setting, press  save current setting of ON/OFF TIMER of timer 1, and enter timer 2 setting. Setting same as timer 1.
8. In timer setting status, press  for 5 seconds to cancel the current timer.
9. No further operation for 60 seconds, save current setting timer, and back to main menu; or press  to save current setting time and back to main menu. (Timers are with power-off memory function.)
10. Timers 2 and 3 setting are same as timer 1.

## F. Check and set parameters (For technician only)

- a. In ON or OFF status, press  for 3 seconds enter the parameter checking menu; press  or  to check parameters.
- b. In parameters checking menu, press  to enter its setting, then press  or  to adjust parameter, press  to save and exit the current setting.
- c. If no operation for 60 seconds, or press  to save and exit setting.

### Parameter Table

No.	Parameters	Range	Default value
L0	Reserved	20°C~60°C	50°C
L2	Reserved	8°C~55°C	40°C
L3	Reserved	2°C~18°C	5°C
L4	Reserved	20°C~60°C	50°C
L5	Cooling setting temperature	8°C~30°C	12°C
L6	Temperature difference	2°C~18°C	5°C
L9	Reserved	30°C~65°C	40°C
L11	Reserved	20°C~60°C	43°C
L12	Reserved	-30°C~35°C	5°C
L14	Reserved	0~90min	30min
L15	Reserved	0~61min	15min
L16	Difference between inlet water temp and outlet water temp	5°C~50°C	13°C
L18	Reserved	0 / 1	1
L19	Reserved	0 / 1 / 2	2
L20	Reserved	24~50	30
L21	Timer 1	0~23	23
L22	Timer 2	0~23	6
L23	Timer 3	0~23	9
L24	Timer 4	0~23	17
L25	Reserved	20°C~75°C	35°C
L26	Reserved	20°C~75°C	42°C
L27	Reserved	20°C~75°C	30°C
L28	Reserved	20°C~75°C	40°C

### G. Status parameters inquiry

In main menu, press  to enter status parameters inquiry. Press  or  to inquire status

parameters; if no further operation for 60 seconds continuously, will back to main menu. Refer to the table below:

No.	Description	Range
00	PCB version	
01	Error code	
02	Reserved	-30°C~99°C
03	Cold water inlet water temp	-30°C~99°C
04	Cold water outlet water temp	-30°C~99°C
05	Environment temperature	-30°C~99°C
06	Return water temperature	-30°C~99°C
09	Current setting	A
10	Compressor 1 current	A
11	Exhaust 1 temperature	0°C~150°C
12	Coil 1 temperature	-30°C~99°C
13	Air return 1 temperature	-30°C~99°C
14	Opening of EEV 1	P
15	Reserved	
20	Compressor 2 current	A
21	Exhaust 2 temperature	0°C~150°C
22	Coil 2 temperature	-30°C~99°C
23	Air return 2 temperature	-30°C~99°C
24	Opening of EEV 2	P
25	Reserved	
30	Compressor 3 current	A
31	Exhaust 3 temperature	0°C~150°C
32	Coil 3 temperature	-30°C~99°C
33	Air return 3 temperature	-30°C~99°C
34	Opening of EEV 3	P
35	Reserved	
40	Compressor 4 current	A

41	Exhaust 4 temperature	0°C~150°C
42	Coil 4 temperature	-30°C~99°C
43	Air return 4 temperature	-30°C~99°C
44	Opening of EEV 4	P
45	Reserved	

## Part IV Maintenance

Before performing any maintenance on the unit, you should turn the unit off first and shut off the power.

Regular maintenance on the unit can make it more efficiency and durable.

Maintenance should be done by qualified technician.

1. Do not use petrol, naphtha, dissolvent and any other chemicals on the unit, otherwise, it may damage the surface.
2. Avoid leaning or putting objects on the device.
3. Keep dry and drafty round the unit.
4. Clean heat exchangers regularly subject to local water quality to keep a good heat exchange efficiency.
4. If the unit will be shut down for a long time, you should drain the water in the pipe, turn the power off and cover it with protective cover, check it roundly before you start it again.
5. Change the installation place

If the wants to change the installation place of the unit, please contact with the dealer or the local Customer Service for help.

## Part V Trouble shooting

**Table 1**

Fault Code	Fault Description	Possible Causes	Treatment
00E	Power sequence failure	<ul style="list-style-type: none"> <li>◇Anti-phase</li> <li>◇Open-phase</li> </ul>	<ul style="list-style-type: none"> <li>◇Anti-phase Exchange two phases.</li> <li>◇Open-phase * Check power supply, the voltage between N &amp; each L line should be 220V, the voltage between two L line should be 380V. * Check the power of PCB. If the voltage is abnormal, check the connection between terminals of main power &amp; phase sequence detection board. * If the error occurs when the unit is running, please check the voltage after compressor starts running, if it is abnormal obviously, then please check the power which is connected to the unit, make sure the power is sufficient and stable, please Install a voltage-stabilizing device if necessary. * If the error still be there, please replace the phase sequence detection board first. * If the error code still be there after the above steps, please replace the PCB.</li> </ul>
01E	Water flow switch fault 1	<ul style="list-style-type: none"> <li>◇Inadequate water-flow</li> <li>◇There is air in the circulating water inlet tube</li> <li>◇Circulation pump destroyed</li> </ul>	<ul style="list-style-type: none"> <li>◇Clean the filter, increase the water-flow</li> <li>◇Discharge the air</li> <li>◇Check and repair the pump and the capacitor</li> </ul>
02E / 02E2 / 02E3	Over current protection	<ul style="list-style-type: none"> <li>◇Over current</li> </ul>	<ul style="list-style-type: none"> <li>◇Check the power supply</li> </ul>
03E / 03E2 / 03E3	High pressure switch protection	<ul style="list-style-type: none"> <li>◇High pressure switch destroyed</li> <li>◇Inadequate water-flow</li> <li>◇The system is jamed, the probe of sensor falls down</li> <li>◇circulating pump damaged</li> <li>◇excessive refrigerant</li> <li>◇some incondensable gas in the refrigerant system</li> </ul>	<ul style="list-style-type: none"> <li>◇Replace the high pressure switch</li> <li>◇Increase the flow</li> <li>◇Check and clean the system, retighten the probe</li> <li>◇Check and repair the circulating pump and the capacitor</li> <li>◇Drain out the superfluous refrigerant</li> <li>◇Drain out the incondensable gas</li> </ul>

04E / 04E2 / 04E3	Low pressure switch protection	<ul style="list-style-type: none"> <li>◇Low pressure switch destroyed</li> <li>◇low refrigerant</li> <li>◇The fins of the evaporator are dirty</li> </ul>	<ul style="list-style-type: none"> <li>◇Replace the low pressure switch</li> <li>◇Check for proper charge and possible refrigerant leak</li> <li>◇Clean the fins</li> </ul>
09E	Communication fault	<ul style="list-style-type: none"> <li>◇Open circuit or short circuit between the controller and PCB</li> </ul>	<ul style="list-style-type: none"> <li>◇Renovate or replace the wire between the controller and PCB</li> </ul>
10E / 10E2 / 10E3	Coil temp sensor fault	<ul style="list-style-type: none"> <li>◇The sensor open circuit/short circuit</li> <li>◇The probe of the sensor falls off</li> <li>◇The plug connected to PCB is bad contact</li> <li>◇The sensor is damaged</li> </ul>	<ul style="list-style-type: none"> <li>◇Renovate/Reconnect the wirings of the sensor</li> <li>◇Probe close to the measured object</li> <li>◇Replace the sensor</li> </ul>
12E	Environment temp sensor fault		
13E	Outlet water temp sensor fault		
14E	Return water temp sensor fault		
15E	Water tank temp sensor fault		
18E / 18E2 / 18E3	Exhaust temp sensor fault		
26E	Inlet water temp sensor fault		
64E / 64E2 / 64E3	Air return temp sensor fault		
20E / 20E2 / 20E3	Exhaust overheat protection	<ul style="list-style-type: none"> <li>◇System is over-load, normal protection</li> <li>◇Inadequate water-flow</li> <li>◇Insufficient of refrigerant</li> </ul>	<ul style="list-style-type: none"> <li>◇Clean the filter, increase the water-flow</li> <li>◇Check leakages and fill refrigerant according rated label.</li> </ul>
40E / 40E2 / 40E3	Compressor under-current protection	<ul style="list-style-type: none"> <li>◇Compressor over-heated</li> <li>◇Compressor wiring falls down, compressor capacitor is damaged</li> <li>◇Low voltage</li> <li>◇Insufficient of refrigerant</li> <li>◇Transformer is damaged</li> <li>◇PCB is damaged</li> </ul>	<ul style="list-style-type: none"> <li>◇Check voltage and power source</li> <li>◇Check leakages and fill refrigerant according rated label.</li> <li>◇Replace transformer</li> <li>◇Replace PCB</li> <li>◇Renovate/Reconnect the wirings of the sensor</li> <li>◇Retighten the probe</li> <li>◇Replace sensor</li> </ul>
52E	Water temperature difference inlet/outlet is too large	<ul style="list-style-type: none"> <li>◇Inadequate water-flow</li> <li>◇The probe of the sensor falls off or damage</li> </ul>	<ul style="list-style-type: none"> <li>◇Clean the filter, increase the water-flow</li> <li>◇Discharge the air</li> <li>◇Check and repair the pump and the capacitor</li> <li>◇Heat exchanger is blocked, repair or replace the heat exchanger</li> </ul>

			<ul style="list-style-type: none"> <li>◇ Check if setting of L16 is correct</li> <li>◇ Re-fix or replace the sensor</li> </ul>
53E	Medium pressure switch protection	<ul style="list-style-type: none"> <li>◇ Leakage of refrigerant</li> <li>◇ Insufficient of refrigerant</li> <li>◇ Electronic expansion valve failure</li> <li>◇ Evaporator is dirty</li> <li>◇ Medium pressure switch is damaged</li> <li>◇ PCB is damaged</li> </ul>	<ul style="list-style-type: none"> <li>◇ Check leakages and fill refrigerant according rated label.</li> <li>◇ Replace electronic expansion valve</li> <li>◇ Clean evaporator</li> <li>◇ Replace medium pressure switch</li> <li>◇ Replace PCB</li> </ul>
16E	Outlet water temperature is too low	<ul style="list-style-type: none"> <li>◇ Inadequate water-flow</li> </ul>	<ul style="list-style-type: none"> <li>◇ Clean the filter, increase the water-flow</li> <li>◇ Discharge the air</li> <li>◇ Check and repair the pump and the capacitor</li> </ul>
76E	Water flow switch fault 2	<ul style="list-style-type: none"> <li>◇ Inadequate water-flow</li> <li>◇ There is air in the circulating water inlet tube</li> <li>◇ Circulation pump destroyed</li> </ul>	<ul style="list-style-type: none"> <li>◇ Clean the filter, increase the water-flow</li> <li>◇ Discharge the air</li> <li>◇ Check and repair the pump and the capacitor</li> </ul>

Note: When fault happen, fault code will be shown on the screen and alarm will sound.

# Part VI Wiring Diagram

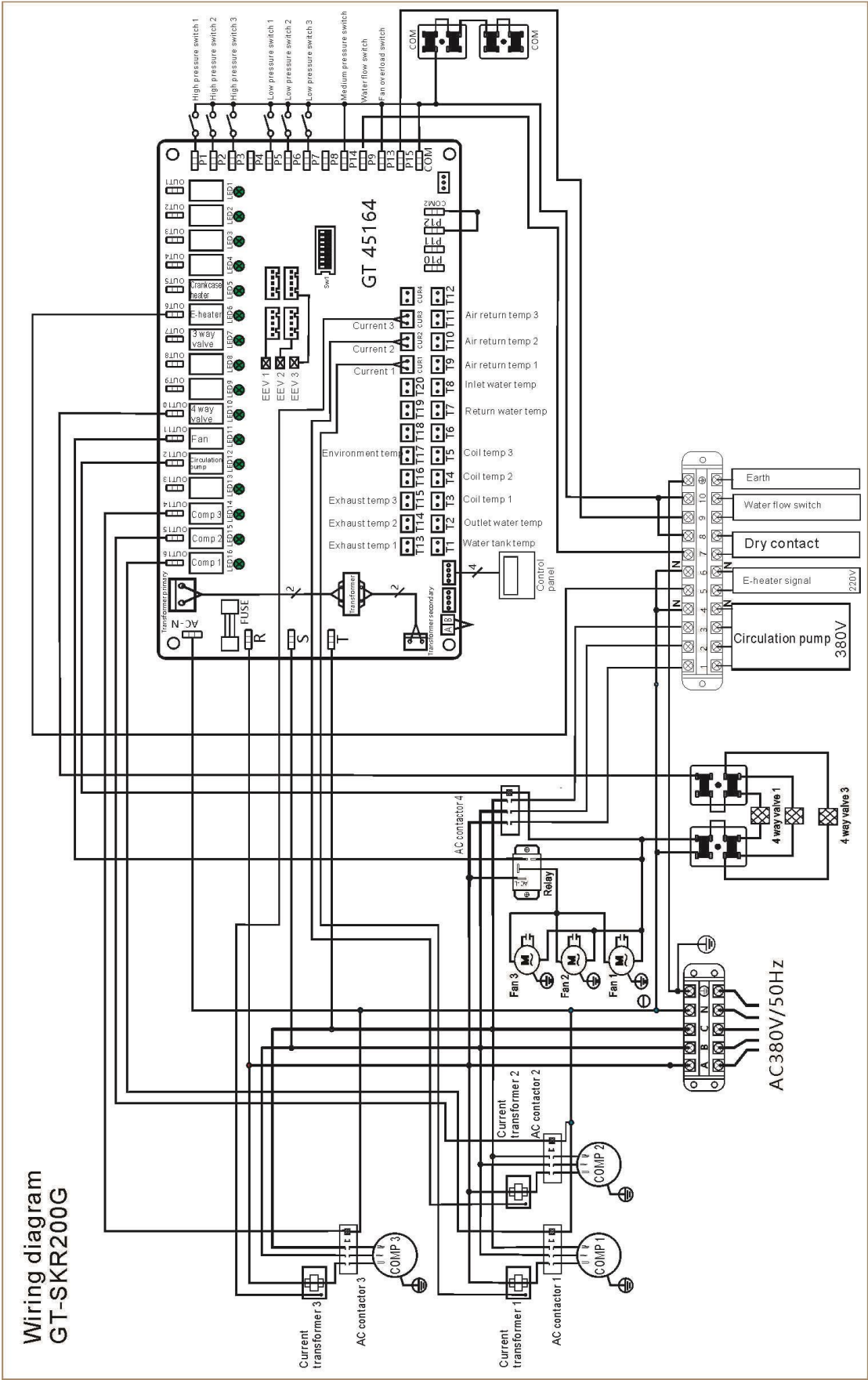

Wiring diagram  
GT-SKR200G

# Wiring diagram GT-SKR300G

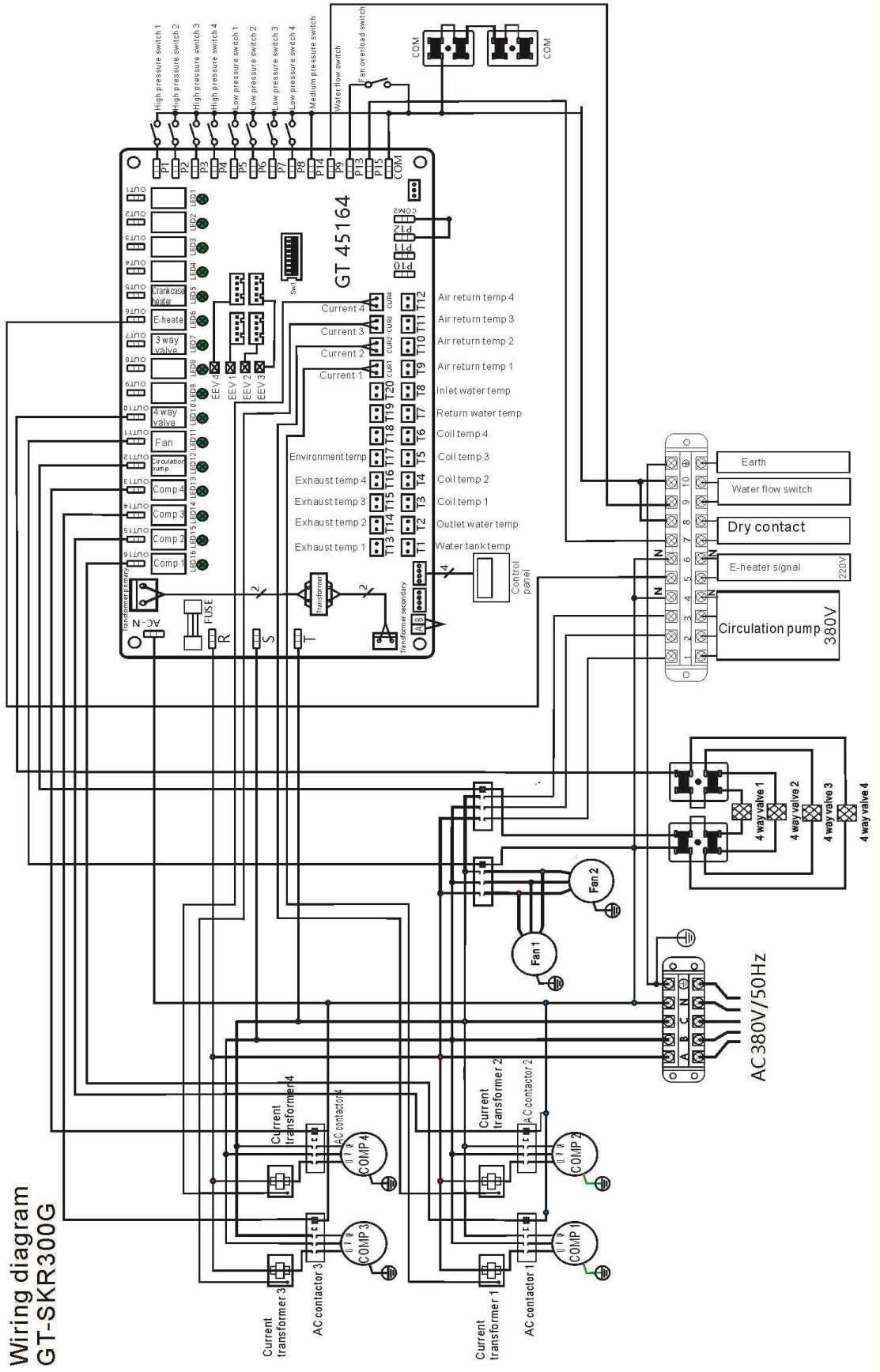

# Disposal

Do not dispose this product as unsorted municipal waste. Collection of such waste separately for special treatment is necessary.

Do not dispose of electrical appliances as unsorted municipal waste, use separate collection facilities.

Contact your local government for information regarding the collection systems available. If electrical appliances are disposed of in landfills or dumps, hazardous substances can leak into the groundwater and get into the food chain, damaging you health and well-being.



There won't be a further notice if anything changes as the unit improved.